

# Technical Specification

agenitor 404BG | ct135/B-0  
Provisional Technical data

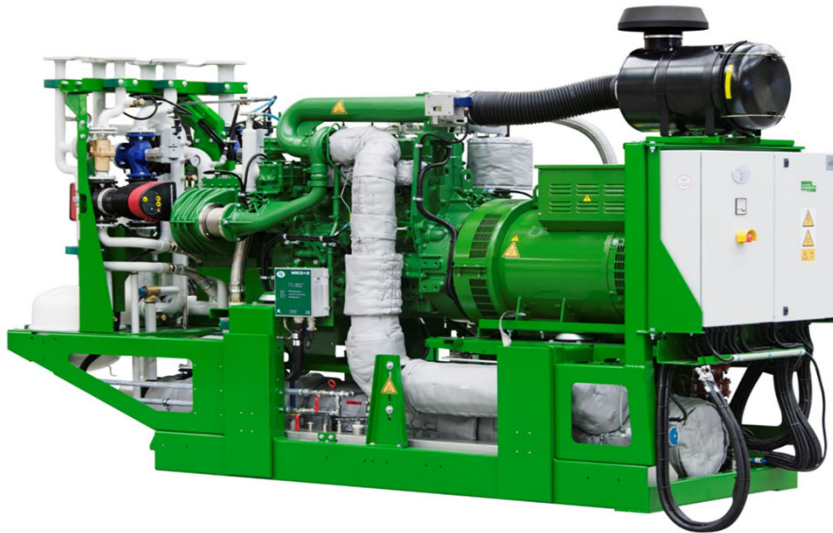

## Version

**180 kW**

**50Hz / 400V**

**Biogas**

**Hi = 4,98 kWh/Nm<sup>3</sup>**

**NOx < 0,5 g/Nm<sup>3</sup> (4) (6)**

**Exhaust cooling system 180 °C**



---

1	Genset	3
1.1	Performance data	3
1.2	Exhaust gas* & sound emissions	3
1.3	Engine	4
1.4	Generator	4
2	Mixture composition	4
2.1	Combustion air	4
2.2	Fuel	5
3	Integrated heat extraction	5
3.1	Heating circuit	5
3.2	Engine circuit:	5
3.3	Low temperature mixture cooling circuit (LT)	5
4	Exhaust system	6
5	Ventilation	6
6	Operating materials	6
7	Electronics and software	6
8	Interfaces	7
8.1	Dimensions and weights	7
8.2	Water/gas interfaces	8
8.3	Electrical connections/interface for energy utilities	8
8.4	Data interfaces	8
9	Technical framework	9

## 1 Genset

1.1 Performance data	50%	75%	100%	Load
Electrical output	90	135	180	kW
Useful thermal output	87	124	161	kW
Rated thermal input	242	337	431	kW
Electrical efficiency	37,2	40,0	41,7	%
Thermal efficiency	35,9	36,9	37,3	%
Total efficiency	73,1	76,9	79,1	%
Power-to-heat ratio	1,04	1,09	1,12	

### 1.2 Exhaust gas\* & sound emissions

NOx with catalytic converter	< 0,5	g/Nm <sup>3</sup> (4)^(6)
NOx without catalytic converter	< 0,5	g/Nm <sup>3</sup> (4)^(6)
CO with catalytic converter	< 0,25	g/Nm <sup>3</sup> (4)^(6)
CO without catalytic converter	< 1	g/Nm <sup>3</sup> (4)^(6)
HCHO with catalytic converter	20	mg/Nm <sup>3</sup> (4)^(6)
HCHO without catalytic converter	< k.A	mg/Nm <sup>3</sup> (4)^(6)
Engine surface noise	103,8	dB
Engine surface noise with soundproof encapsulation	70	dB(A)
Exhaust outlet noise **	121,5	dB

### 1.3 Engine

Engine manufacturer	2G	
Engine type	agenitor 404	
Model/cylinders	R / 4	
Mode of operation	4-stroke	
Combustion process	$\lambda > 1$	
Engine displacement	8.000	ccm
Bore / Stroke	130 / 150	mm
Rated speed	1.500	1/min
ISO coefficient of performance (mech.)	188	kW
Compression ratio	13,6:1	
Mean effective pressure	18,8	bar
Mean piston speed	7,5	m/s
Flywheel body	SAE 1	
Direction of flywheel rotation	left	
Number of crown gear teeth	167	
Unladen engine weight	950	kg
Mixture cooling system	50	°C

\*

\*\* Total sound power level at engine operation at full load according to DIN EN ISO 3746

\*\*\* Mean sound pressure level at a distance of 1 m under free field conditions according to DIN 45635. Increased noise exposure is to be expected with a fresh air intake from the installation room

## 1.4 Generator

Manufacturer	Leroy Somer	
Type	LSA 46.3 M7 / 4P	
Generator type	Synchronous, directly coupled	
Automatic voltage regulator (AVR)	D510 C	
Rated engine speed	1500	1/min
Frequency	50	Hz
Mechanical input power	188	kW
Effective electrical output	180	kW
Apparent electrical output (Cos $\varphi$ 1/0.9)	180 / 200	kW
Rated generator current (Cos $\varphi$ 1/0.9)	260 / 289	A
Rated generator voltage (+/-10%)	400	V
Subtransient reactance X"d	10,5	%
Short-circuit current Ik"3	3,44	kA
Power factor Cos $\varphi$ (inductive/capacitive)	0,9 / 0,9	
generator protection relay circuit breaker	400	
Efficiency (full load at Cos $\varphi$ 1)	95,5	%
Moment of inertia	2,37	kg · m <sup>2</sup>
Max. ambient temperature	40	°C
Stator coupling	star	
Protection class	IP23	
Generator weight	754	kg
Power factor correction	not available	
Engine startup	not available	

## 2 Mixture composition

### 2.1 Combustion air

Combustion air mass flow rate	915	kg/h
Combustion air volume flow rate (25°C/1013 mbar)	773	m <sup>3</sup> /h

### 2.2 Fuel

Fuel requirements according to "TA-004 Gas"

Reference methane number/minimum methane number **	150 / 135	-
Fuel mass flow rate	116,6	kg/h
Fuel volume flow rate	86,5	m <sup>3</sup> /h
Min. gas flow pressure at rated load*	30	mbar
Max. gas flow pressure at rated load*	70	mbar
Gas train safety pressure	500	mbar

\* At gas train inlet

### 3 Integrated heat extraction

#### 3.1 Heating circuit

Heating water requirements according to "TA-002 Heating circuit"

Heating water volume flow rate (delta T = 20K)	7,7	m <sup>3</sup> /h
Heating water return temperature(max.)*	70	°C
Heating water supply temperature (max.)**	88	°C
Safety valve	6	bar
Min. operating pressure	1	bar
Internal pressure drop in heating circuit *	480	mbar
Approx. pressure reserve*	420	mbar

#### 3.2 Engine circuit:

Coolant requirements according to "TA-001 Coolant"

Cooling water heat (engine & exhaust gas)	64,0	kW
Engine cooling water inlet temperature (min.)	80	°C
Engine cooling water outlet temperature (max.)	90	°C
Max. inlet/outlet difference	6	°C
Recirculated engine cooling water volume (min.)	10,7	kg/h
Total recirculated cooling water volume	20,6	kg/h
Max. operating pressure	2	bar
Min. operating pressure	1	bar
Safety valve	3	bar
Approx. heat dump circuit pressure reserve (optional) *	250	mbar
Safety temperature limiter	110	°C
Mixture heat from high temperature circuit (HT)	30	kW
Mixture coolant inlet temperature HT (max.)	82	°C
Recirculated coolant volume HT mixture (min.)	10,0	kg/h

#### 3.3 Low temperature mixture cooling circuit (LT)

Coolant requirements according to "TA-001 Coolant"

Mixture heat LT	16,4	kW
Mixture coolant inlet temperature LT	38 / 43	°C
Mixture coolant outlet temperature LT	41 / 46	°C
Recirculated coolant volume LT mixture (min.)	5,5	kg/h
Safety valve	3	bar
Min. operating pressure	1	bar
Approx. pressure reserve *	350	mbar

\* From/to module interface

\*\* Exhaust system

#### 4 Exhaust system

Exhaust gas temperature after turbine	390	°C
Exhaust gas temperature after exhaust gas heat exchanger	180	°C
Exhaust gas heat	67	kW
Damp exhaust gas volume flow rate	789	m <sup>3</sup> /h
Dry exhaust gas volume flow rate	707	m <sup>3</sup> /h
Damp exhaust gas mass flow rate	1.032	kg/h
Dry exhaust gas mass flow rate	962	kg/h
Max. exhaust backpressure after turbocharger	52(34)	mbar
Approx. pressure reserve (with catalytic converter) *	8	mbar

#### 5 Ventilation

Radiant module heat (ca.)	35	kW
Min. supply air flow rate ( $\Delta t = 15$ K)	7.832	m <sup>3</sup> /h

#### 6 Operating materials

Lubricating oil approvals, see 'TA-003 Lubricating oil'

Lubricating oil consumption ( $\emptyset$ /max.)	0,1 / 0,3	g/kWh
Engine oil capacity (max.)	24	ccm
Lubricating oil refill tank capacity (optional)	95	l
Lubricating oil system with auxiliary tank (optional)	95	l
Approx. engine circuit coolant capacity (Module)	95	l
Approx. LT mixture cooling circuit coolant capacity (Module)	12	l
Coolant approvals, see "TA-001 Coolant"		

#### 7 Electronics and software

Power system protection device	Bachmann GSP	
Power system protection software status	> 13412	
Touch screen	10	
Approval (depending on version)	VDE-AR-N 4105 / VDE-AR-N 4110	
Control cabinet protection class	IP 54	
Power distribution cabinet protection class	IP 54	
Ambient temperature of control cabinets	0 - 35	°C
Relative humidity of control cabinets (max.)	65	%

\* From module interface (exhaust gas heat exchanger/catalytic converter as standard version and in new condition)

## 8 Interfaces

### 8.1 Dimensions and weights

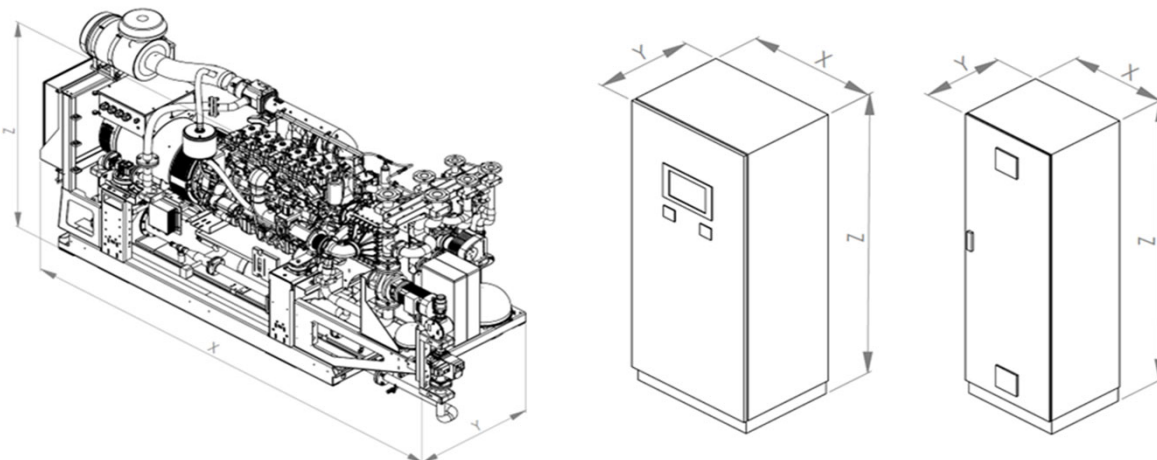

Module Length *	3675	mm
Module Width *	1110	mm
Module Height *	2100	mm
Module Weight (without operating materials)	3980	kg
Module Weight with soundproof encapsulation (optional)	4930	kg
Powder-coated CHP frame	RAL 6002	
Control cabinet Width	800	mm
Control cabinet Depth	500	mm
Control cabinet Weight	1900	mm
Control cabinet Weight	190	kg
Powder-coated control cabinet	RAL 7035	
Power distribution cabinet Width	600	mm
Power distribution cabinet Depth	400	mm
Power distribution cabinet Height	1900	mm
Power distribution cabinet Weight	140	kg
Powder-coated power distribution cabinet	RAL 7035	

### 8.2 Water/gas interfaces

Gas interface	50 / 10
Exhaust gas interface	150 / 10
Heating circuit interface	50 / 16
Heat dump circuit interface	65 / 16
LT mixture cooling circuit interface	40 / 16

### 8.3 Electrical connections/interface for energy utilities

Grid connection with pre-fuse (provided by customer)	50Hz / 400V
Electricity network system	TN-S
Short-circuit current rating I <sub>cc</sub> (max.)	50

\* Deviating dimensions for version with soundproof encapsulation

---

## 8.4 Data interfaces

Remote maintenance access (optional) *	DSL / UMTS (SIM)
Interfaces/data interfaces (optional)	<ul style="list-style-type: none"><li>- Profibus DP</li><li>- Profinet IO</li><li>- Modbus RTU</li><li>- Modbus TCP</li><li>- Ethernet IP</li><li>- hardware signals</li></ul>
Virtual Power Plant access (optional)	Possible after technical clarification (bus systems or hardware signals)

---

\* The remote maintenance access must be provided by the customer



## 9 Technical framework

Unless otherwise indicated, all data refer to engine operation at full load at the respective media temperatures and apply subject to technical innovations.

The electrical output is based on the generator output measured at the generator terminals.

Therefore, all output and efficiency specifications are gross values.

The fuel gas quality must meet the requirements of "TA-004 Gas". The equipment and peripheral systems must be configured according to the "Technical Manuals" by 2G.

- (1) Reference conditions according to DIN ISO 3046-1. At nominal output, the specific fuel consumption tolerance amounts to +5%. Efficiency data is based on an engine in new condition. The decrease in efficiency throughout the service life is reduced by adhering to the maintenance guidelines.
- (2) At nominal output, the useful thermal output tolerance amounts to  $\pm 8\%$ .
- (3) Specifications based on new condition. The exhaust gas temperature tolerance amounts to  $\pm \{$
- (4) In reference to a residual oxygen content in the exhaust gas of
- (5) Electrical output at the generator terminals at  $\text{Cos } \varphi = 1$ .
- (6) Volume specifications in standard condition:

Pressure	1013 mbar
Temperature	0 °C
- (7) Reproducibility standard deviation of 4 dB according to DIN EN ISO 3746
- (8) The heating water supply temperature tolerance amounts to  $\pm 1$  °C.

The performance data in this document are based on standard reference conditions.

### Standard reference conditions according to DIN ISO 3046-1:

Air pressure	1000 mbar
Air temperature:	25 °C
Relative humidity	30 %

### Derating

In case of installation at altitudes  $> 100$  and/or intake air temperatures  $> 25^{\circ}\text{C}$  the project-specific derating must be determined according to "TI-049 Derating".